



DIMENSION	mm	inch
P	50.8	2.00
M	4.00	0.16
L	11.5	0.45
H	23.0	0.91
GC (Straight)	59.5	2.34
GC (Curve)	56.8	2.23

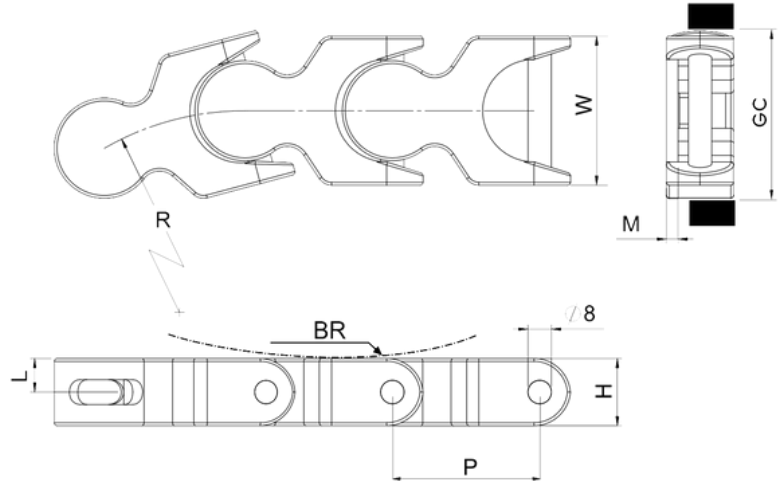
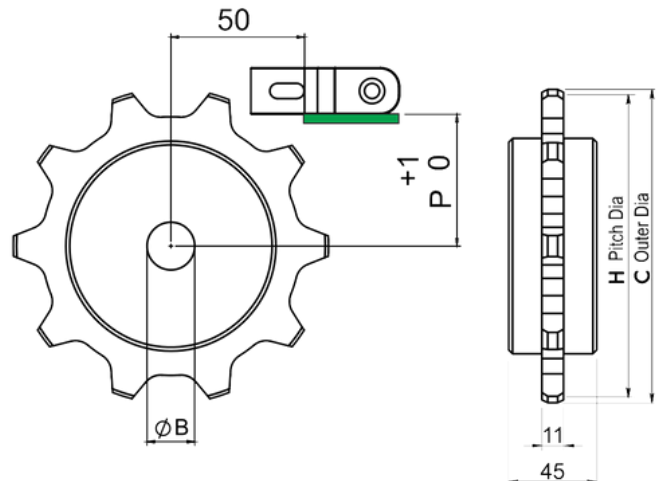

Plate Materials : Polyacetal
Pin Material : Austenitic steel

SP-1702 (Multi-flex Chain)

	Width W		Working Load (N)	Radius (R)		Backflex Radius (BR)		Weight (kg/m)
	(mm)	(inch)		(mm)	(inch)	(mm)	(inch)	
SP-1702	51.0	2.007	2669	147	5.79	50	1.97	1.55

SP-1702 SPROCKETS



TEETH (Z)	C	H	P	M/C
8	132.8	130.7	53.0	■
10	165.1	161.8	69.0	■
13	215.2	209.0	93.5	■

BORE (B) - Ø 25,30,35,40

