

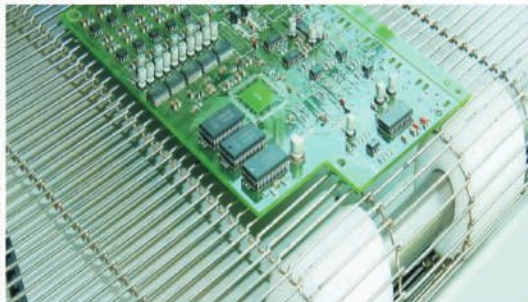

# B PLASTICS AUSTRALIA

ENGINEERING AND PLASTICS SPECIALIST

The Trusted Wire Mesh Belt Manufacturer™



# B PLASTICS AUSTRALIA

ENGINEERING AND PLASTICS SPECIALIST

## BALANCED WEAVE BELT

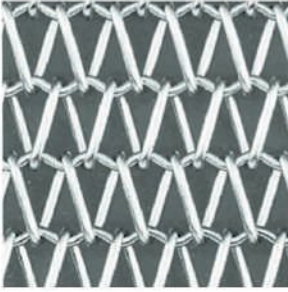

Balanced weave belts are a series of left and right hand wire mesh spirals connected by a crimped rod to create a balanced weave that is straight tracking. It is the most versatile belt used in a variety of industries. Some balanced weave belts are positively driven by a sprocket or a pinroll. Balanced weave belts can be manufactured to match new or existing pinrolls and are available in a wide range of specifications.

Interlock Mesh Belts's balanced weave belts deliver better stability, heavier loads and increased surface area. Balanced weave belts are often the heart and soul of many bakeries and snack food operations. It is an economical weave with high tensile strength and minimal tendency to track to either side of the drive pulley, which makes this belt suitable for many applications.

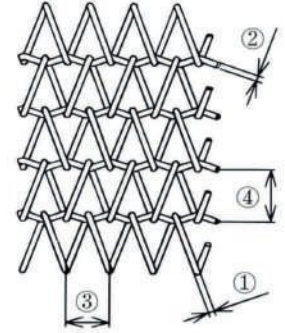

1. Spiral Wire Dia  
2. Cross Wire Dia  
3. Spiral Wire Pitch  
4. Cross Wire Pitch

Specification	No. of spirals per foot	No. of cross rods per foot	Spiral Wire Dia (mm)	Cross Wire Dia (mm)
B-12-12-12-10	12	12	2.642	3.251
B-18-16-12-12	18	16	2.642	2.642
B-36-24-16-14	36	24	1.626	2.032
B-48-32-16-16	48	32	1.626	1.626
B-60-32-16-16	60	32	1.626	1.626
B-60-48-16-14	60	48	1.626	2.032
B-55-90-18-18	55	90	1.219	1.219
B-72-24-16-14	72	24	1.626	2.032
B-72-42-16-16	72	42	1.626	1.626

\*\* Many additional standard and custom specs with various combinations of pitches and wire diameter other than the above can be specially made as per customers demand.

Type	Specification	No. of spirals per foot	No. of cross rods per foot	Spiral Wire Dia (mm)	Cross Wire Dia (mm)
LK 3	B-55-90-18-18	55	90	1.219	1.219
LK 4	B-76-40-18-18	76	40	1.219	1.219
LK 5	B-60-40-16-16	60	40	1.626	1.626
LK 6	B-36-30-16-16	36	30	1.626	1.626
LK 7	B-24-24-16-16	24	24	1.626	1.626
LK 8	B-48-30-16-16	48	30	1.626	1.626
LK 9	B-18-10-08-06	18	10	4.064	4.877
LK 16	B-36-22-12-12	36	22	2.642	2.642
LK 17	B-24-20-12-10	24	20	2.642	3.251
LK 17DC	B-30-55-12-12	30	55	2.642	2.642
LK 19	B-24-18-12-10	24	18	2.642	3.251
LK 52	B-122-76-20-18	122	76	0.914	1.219

## COMPOUND BALANCED BELT



Compound balanced belt is produced with right-and left-hand spirals fitted closely together for a smooth, dense weave generally assembled with a straight connecting rod. The Compound balanced belts offer the tightest design of any woven wire belt. The design has a smooth carrying surface to carry very fine or heavy products.

Compound balance weave belts are extensively used in the Heat Treat Industry for fasteners as well is in the baking industry for cookies, Snack Foods and Crackers.

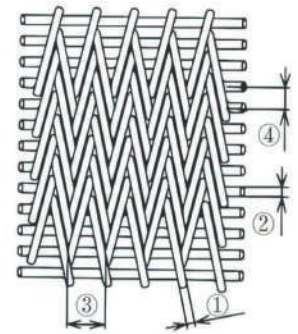

1. Spiral Wire Dia  
2. Cross Wire Dia  
3. Spiral Wire Pitch  
4. Cross Wire Pitch

Specification	No. of spirals per foot	No. of cross rods per foot	Spiral Wire Dia (mm)	Cross Wire Dia (mm)
CB3-24-55-12-10	24	55	2.642	3.251
CB3-30-72-14-14	30	72	2.032	2.032
CB3-36-70-14-14	36	70	2.032	2.032
CB3-60-132-19-19	60	132	1.016	1.016

\*\* Many additional standard and custom specs with various combinations of pitches and wire diameter other than the above can be specially made as per customers demand.

## DOUBLE BALANCED WEAVE BELT



Double balanced metal (mesh) belt is similar to the balance weave construction, however it incorporates pairs of right and left hand spiral joined at crimped or straight rods. A modified variation of balance weave, using two interwoven spirals. Two 12 pitch spirals are woven together to form a 24 pitch belt.

This construction offers straight tracking and greater strength than a balance weave belt. These belts are often used for air flow and or where there is a need for clearance for cleaning purposes most commonly used in elevated temperature applications for Sintering, Brazing and Annealing.

Specification	No. of spirals per foot	No. of cross rods per foot	Spiral Wire Dia (mm)	Cross Wire Dia (mm)
DB-24-20-12-10	24	20	2.642	3.251
DB-24-22-18-16	24	22	1.219	1.626
DB-36-23-16-14	36	23	1.626	2.032
DB-30-18-16-14	30	18	1.626	2.032

\*\* Many additional standard and custom specs with various combinations of pitches and wire diameter other than the above can be specially made as per customers demand.

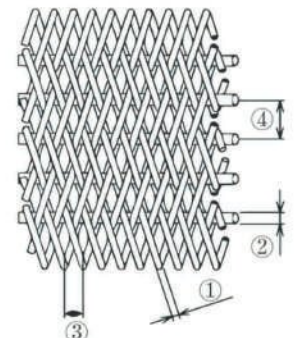

1. Spiral Wire Dia  
2. Cross Wire Dia  
3. Spiral Wire Pitch  
4. Cross Wire Pitch

## GRATEX BELT

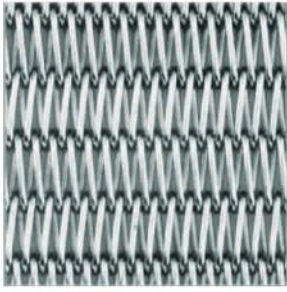

Gratex Belts are similar to balanced weave construction. It is produced by right and left hand spiral and is more closely joined by straight connector rods to produce a stronger semi close mesh to carry small parts and heavy loads. This results in a stronger construction and reduced the possibility of product being retained in the mesh, while retaining the basic advantages of the Balanced weave.

Specification	No. of spirals per feet	No. of cross rods per feet	Spiral Wire Dia (mm)	Cross Wire Dia (mm)
G-36-10-10-06	36	10	3.251	4.877
G-42-10-10-06	42	10	3.251	4.877
G-42-18-10-10	42	18	3.251	3.251
G-96-20-19-16	96	20	1.016	1.626
G-96-48-18-16	96	48	1.219	1.626
G-144-20-19-16	120	62	1.016	1.626

\*\* Many additional standard and custom specs with various combinations of pitches and wire diameter other than the above can be specially made as per customers demand.

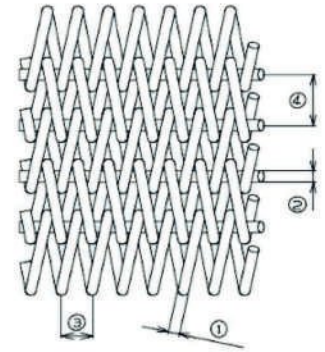

1. Spiral Wire Dia  
2. Cross Wire Dia  
3. Spiral Wire Pitch  
4. Cross Wire Pitch

## DUPLEX BELT \ ROD REINFORCED BELT

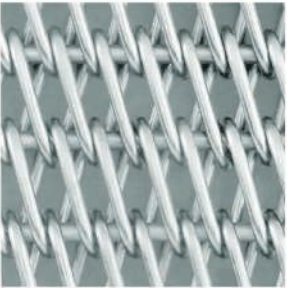

Both Duplex belts and Rod Reinforced Belts are produced by straight re-inforcing rod between pair of single weave belt. Duplex Belt has very small opening and these types of belts have high strength. Whereas Rod Reinforced Belts have large opening to reduce longitudinal stretch and contraction under high temperature. These belts are efficient for the carrying of small parts such as needle bearings, lock washer, and similar products, for quench tank belts handling small parts.

Specification	No. of spirals per feet	No. of cross rods per feet	Spiral Wire Dia (mm)	Cross Wire Dia (mm)
D-126-76-18-16	126	76	1.219	1.626
D-72-48-16-16	72	48	1.626	1.626
R-18-18-12-12	18	18	2.642	2.642
R-24-18-12-12	24	18	2.642	2.642

D-Duplex belt (Small Opening)

R-Rod Reinforced Belt (Large Opening)

\*\* Many additional standard and custom specs with various combinations of pitches and wire diameter other than the above can be specially made as per customers demand.

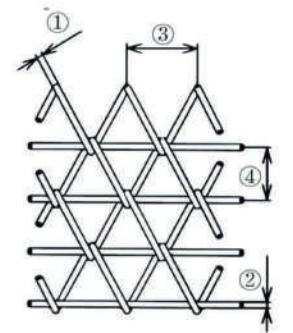

1. Spiral Wire Dia  
2. Cross Wire Dia  
3. Spiral Wire Pitch  
4. Cross Wire Pitch

## CHAIN LINK \ CONVENTIONAL BELT



Conventional link belts are a series of right or left hand spiral each turned into the previous spiral to form a conventional belt similar to a diamond mesh wire cloth. It is the simplest version of universal weave conveyor belt. This design provides large open area to enhance the efficiency of product washing and drying process.

As per your request, Conventional link belts are available with a rod through the intersection point of the spirals for added strength.

Specification	Spiral Mesh Spacing (inch)	Spiral Wire Dia (mm)
C-12-12	2	2.642
C-24-18	2	1.219
C-24-16	2.5	1.626
C-30-16	1	1.626

\*\* Many additional standard and custom specs with various combinations of pitches and wire diameter other than the above can be specially made as per customers demand.

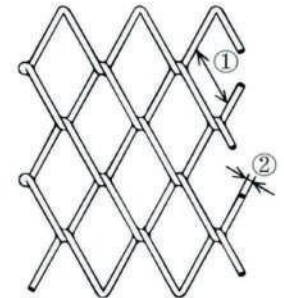

1. Spiral Mesh Spacing  
2. Spiral Wire Dia

## Z 47 WIRE BAND \ BISCUIT BELT

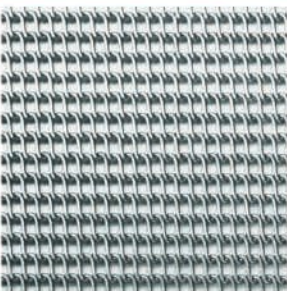

The Z-47 Wire Band Belt or Z-47 Biscuit Belt is a highly usable conveyor belt for the bakery industry. The belt has been designed especially for baking biscuits directly on the belt in straight feed through ovens. Its name is based on the Z shape of the flattened spirals.

The Z-47Belt is a stratified metal spiral belt with a light weight and a reduced thickness. Its design gives the belt low heat inertia, high strength and a good air circulation through the belt. The Z-Belt is made of specially selected Carbon Steel for a good and even baking result and are mostly used in production processes with temperatures of +200°C to +275°C.

Specification	Spiral Pitch (mm)	Cross Pitch (mm)	Spiral Wire Dia (mm)	Belt Thickness (mm)
Z-47	4	5.4	1.219	2.4

\*\* Many additional standard and custom specs with various combinations of pitches and wire diameter other than the above can be specially made as per customers demand.

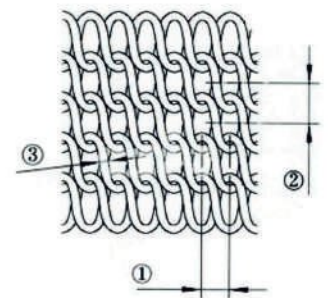

1. Spiral Pitch  
2. Cross Pitch  
3. Spiral Wire Dia

### HONEY COMB BELT



### EYE LINK BELT

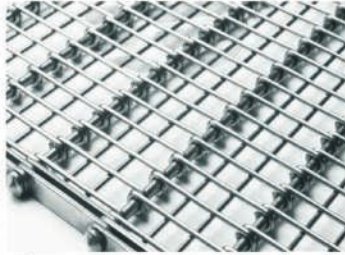

### ENROBER BELT

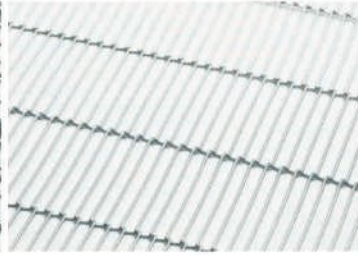

### TURNING BELT



\*\* Kindly contact us for detailed specifications of the above mentioned models.

### BELT EDGE TREATMENT

#### WELDING TYPE



#### HOOK EDGE TYPE

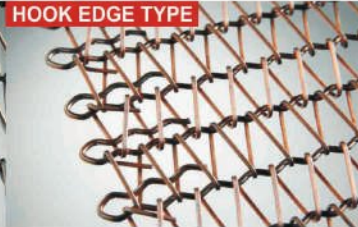

#### LADDERED EDGE TYPE



#### CHAIN ATTACHMENT TYPE



\*\* Kindly contact us in case of need of custom designed models based on your requirements.

### CHAIN DRIVEN BELT WITH ROLLER CHAINS AND ATTACHMENTS



\*\* Roller Chains are available in standard chain pitches like 3/8", 1/2", 5/8", 3/4", 1", etc using standard M.S Chains and S.S Chains with Anti-Corrosive and Heat Resistant features as per requirements. Other non standard chains and special chains upto 4" are also available on demand.

### INDUSTRIES SERVED

Decorating Lehr  
Enameling Units  
Leaf Spring units  
Glazing & Coating Units  
Heating & Freezing Units  
Cladding & Forging Units  
Sintering & brazing Furnace  
Harding & Tempering Furnace  
Glass Annealing Lehr Industries

Textile  
Frying  
Foundry  
Metallurgy  
Recycling  
Agriculture  
Automotive  
Confectionaries  
Breeding/Crumbling

IS Machines  
Drying Ovens  
Cooling Tunnels  
Quienching Tanks  
Shot Blasting Machine  
Shrink Packing Machine  
Noodle Making Machine  
Chappathi Making Machine  
Circuit Board dedicated device

Salt Industries  
Tyre Industries  
Veneer industry  
Ceramic Industries  
Plywood Industries  
Refrigerator Facilities  
Metal Working Industries  
Pharmaceutical Industries  
Food Processing Industries

### MATERIAL USED

High Carbon Steel, G.I, SS 304, SS 304 L, SS 310, SS 310S, SS 314, SS 316, SS 316 L, SS 321, SS 209, SS 330, INCONEL 600, etc

\* Kindly contact us in case of any special grade materials is to be used based on your requirements.

### ABOUT US

Interlock Mesh Belts is a group company of Spectra Plast India Pvt Ltd engaged in manufacturing Wire Mesh Conveyor Belts. The company is a pioneer in the development of metal conveyor belts in India and serves customers ranging from food processing to aerospace, both in India and abroad. We ensure a fit for purpose advice to our clients by maintaining high standards in terms of production, quality & services with the experience and extensive knowledge of our engineers and sales advisors.

Each customers has a unique set of criteria surrounding their wire belting need. Interlock Mesh Belts offers many styles and specifications of conveyor belts to suit your specific application and improve your process efficiencies. The products above represent only a sample of our capabilities as many of our designs are proprietary. Please call or E-mail us to learn how we can design the perfect belt to meet your needs.