

DIMENSION	mm	inch
P	38.1	1.50
O	61.1	2.40
L	7.60	0.30
H	20.0	0.78
E	7.10	0.28
T	4.00	0.15
V	11.50	0.45
s	16.0	0.63
M	42.9	1.68
D	45.0	1.77

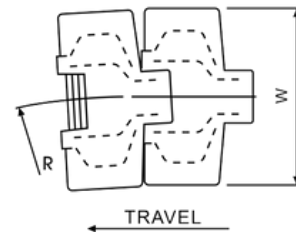
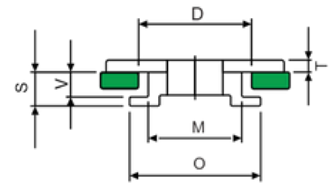
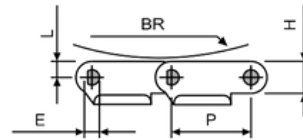

**Plate Materials :** polyacetal  
**Pin Material :** Austenitic steel

**SP-880TAB (Turning Plastic Chain)**

	Width W (mm)	Width W (inch)	Working Load (N)	Radius(R) (mm)	Backflex Radius(BR) (mm)	Weight (kg/m)
SP-880TAB K325	82.5	3.25	2100	500	40	0.94
SP-880TAB K450	114.3	4.50	2100	610	40	1.08

standard length : 80 pitches (10 feet - 3.048 m)



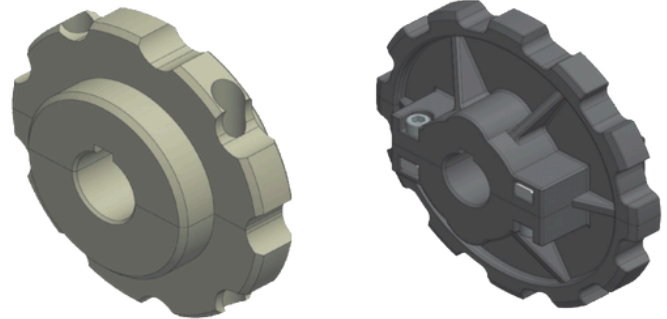
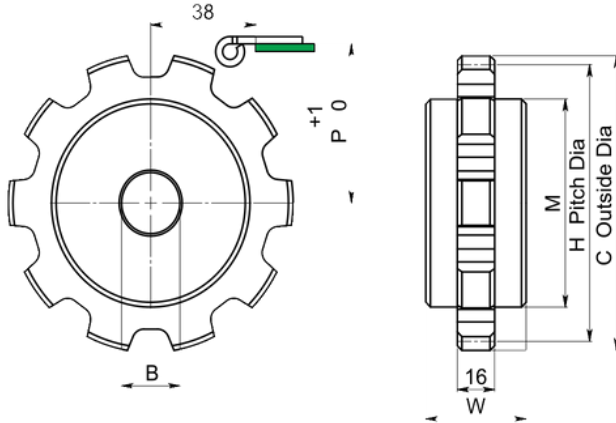

WIDTH (W)- 42.5 mm FOR M/C SPROCKET ,M/C SPLIT SPROCKET  
AND 50 mm FOR MOULDED SPROCKET

**MATERIAL : POLYAMIDE**

**SP-880TAB (SPROCKET)**

CODE	TEETH (Z)	C	H	P	M	M/C	M/C SPLIT	MOULDED SPLIT
SP-880TAB S 9	9	110.0	111.4	59.30	76	■	■	
SP-880TAB S 10	10	122.0	123.3	65.25	88	■	■	■
SP-880TAB S 11	11	135.0	135.2	71.20	92	■	■	
SP-880TAB S 12	12	147.3	147.2	77.20	105	■	■	■

BORE (B) - Ø 25,30,35

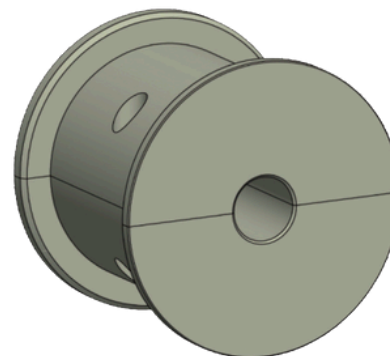
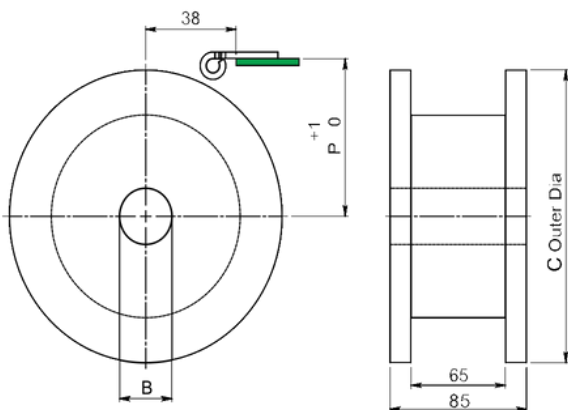

**MATERIAL : POLYAMIDE**

**SP-880TAB (IDLER)**

CODE	TEETH Z	C	P	M/C	M/C SPLIT
SP-880TAB I 9	9	117.0	62.6	■	■
SP-880TAB I 10	10	129.8	68.6	■	■
SP-880TAB I 11	11	142.2	74.6	■	■
SP-880TAB I 12	12	154.7	80.5	■	■

BORE (B) - Ø 20,25,30,35





## CHAIN POSITIONING FOR SINGLE ROW

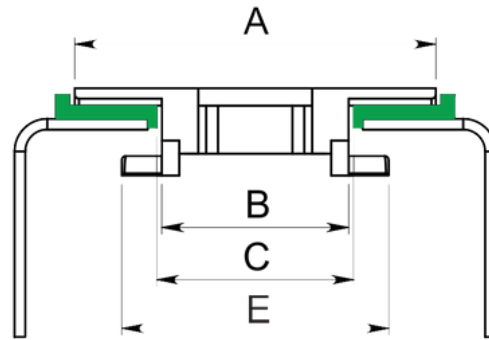

## CHAIN POSITIONING FOR MULTIPLE ROW

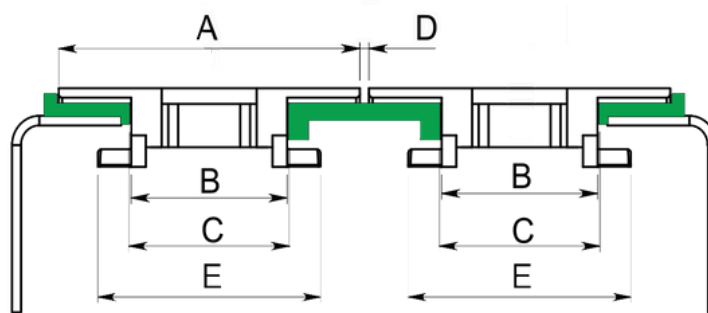

### SP-880TAB (CHAIN POSITION)

CHAIN CODE	A	B	C	D	E
SP-880TAB K325	82.5	42.9	46.0	2.5	61.1
SP-880TAB K450	114.3	42.9	46.0	2.5	61.1



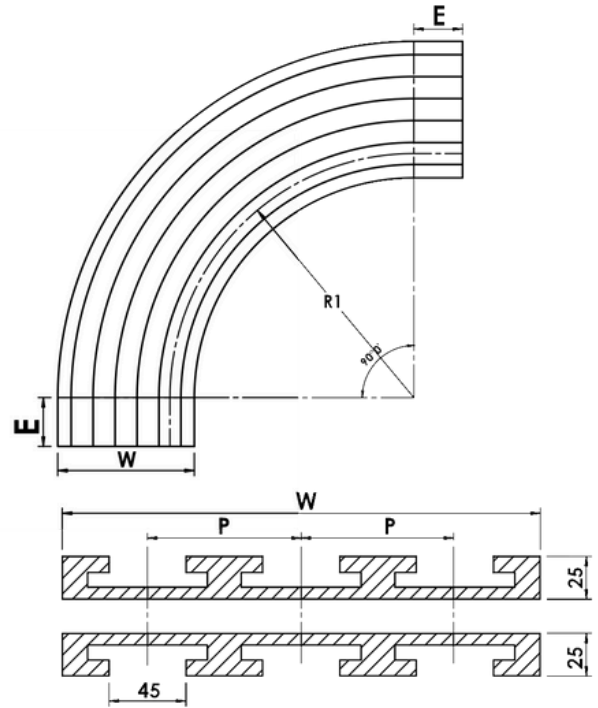
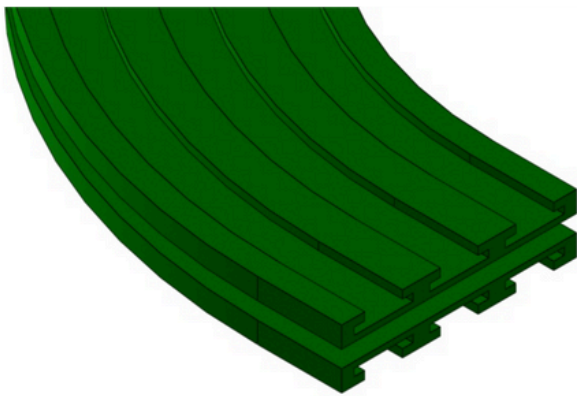

Material : UHMWPE

Color : ●●

**SP-880 TAB CORNER TRACK**

Chain Type	Tracks	Width (W)
K325 PITCH (P) - 85 mm RADIUS (R1) - 500, 610,650,800,1000 E = 50 & 100 mm	1	100
	2	185
	3	270
	4	355
	5	440
	6	525

Chain Type	Tracks	Width (W)
K450 PITCH (P) - 120 mm RADIUS (R1) - 610, 650,800,1000 E = 50 & 100 mm	1	130
	2	250
	3	370
	4	490
	5	610
	6	730

Total track width = (p x (no.of track -1))+ Basic width

Basic width = single track width

