

DIMENSION	mm	inch
P	62.5	2.46
H	28.0	1.10
T	14.0	0.55

Plate Materials : polyacetal
Pin Material : Austenitic steel

SP-CC600 (Crate Chain)

	Width W (mm)	Width W (inch)	Working Load (N)	Radius (R) (mm)	Radius (R) (inch)	Backflex Radius (BR) (mm)	Backflex Radius (BR) (inch)	Weight (kg/m)
SP-CC 600	42.0	1.65	3950	457	17.9	50	1.97	1.20

SP-CC 600 SPROCKETS

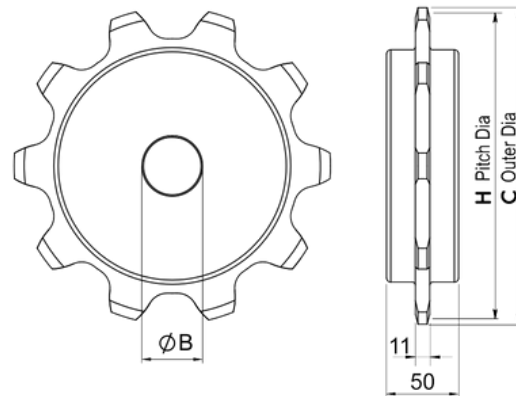

TEETH (Z)	C	H	M/C
8	172.0	166.0	■
10	215.0	205.0	■
12	256.0	246.0	■
14	297.0	286.0	■

BORE (B) - Ø 25,30,35,40

